

THERMAflow[®]

ELECTRIC COMBINATION BOILER

(Patent Pending. Design Right Protected.)

TH12/210U, TH12/250U & TH12/330U
TH9/210U, TH9/250U & TH9/330U

(INCLUDES SOLAR APPENDIX)

This product is suitable for connection to ~230-240V, 50Hz

INSTRUCTIONS FOR USE, INSTALLATION AND SERVICING

TO BE LEFT WITH THE USER

The instructions consist of three parts; **User**, **Installation** and **Servicing** instructions, which include the guarantee registration card.

The instructions are an integral part of the appliance and must, to comply with the current issue of the building, electrical regulations and water by-laws, be handed to the user on completion of the installation.

GUARANTEE REGISTRATION

Thank you for installing a new Thermal Innovations product in your home.

Thermal innovations appliances, are manufactured to the very highest standards so we are pleased to offer our customers, a comprehensive first year guarantee and a second year parts guarantee.

In the instruction envelope is to be found your guarantee registration card, which must be completed and returned to Thermal Innovations (UK) Ltd or register your Thermal Innovations (UK) Ltd appliance for 1st year guarantee protection by calling the below number.

Our guarantee gives you peace of mind valuable protection against breakdown by covering the cost of-

- All replacement parts
- All labour charges
- All call-out charges

THERMAL INNOVATIONS (UK) LTD

31-39 Napier Court, Cumbernauld, Glasgow, G68 0LG

Customer services

Tel +44 (0) 870 850 5207

Fax +44 (0) 870 850 5208

Web www.thermaflowheating.co.uk

Issue Number: 1b Issue date: December 2009

Copyright Notice

This document contains proprietary information protected by copyright, and this Manual and documentation are copyrighted. All rights are reserved. No part of this document may be photocopied or reproduced by mechanical, electronic, or other means in any form without permission from Thermal Innovations (UK) Ltd.

© Copyright Thermal Innovations (UK) Ltd 2006-09 -All rights reserved.

Contents

0.1	Instructions general	4
0.2	Draining & Filling	5
0.3	Manual Handling Guidance	5
0.4	TESTING & CERTIFICATION	5
0.5	THE UNIT LOCATION	5
Part1	- INSTRUCTIONS FOR USE	7
1.1	INTRODUCTION.....	7
1.2	Domestic hot water temperature	7
1.3	To turn the boiler off.....	7
1.4	Maintenance and servicing	7
1.5	Clearances	7
1.6	Draining and filling.....	8
1.7	Replacement parts	8
1.8	GENERAL DATA.....	9
Part 2	- INSTALLATION	11
2.1.1	Sheet metal parts	11
2.1.2	Statutory requirements	11
2.1.3	DATA 11	
2.1.4	ELECTRICAL SUPPLY.....	11
2.1.5	Electrical supply	12
2.1.6	Heating system controls	12
2.2.1	Boiler Position.....	12
2.2.2	Boilers in a compartment.....	13
2.2.3	Clearances	14
2.3.1	General notes	14
2.3.2	Safety valve	14
2.3.3	Pressure Gauge	14
2.3.4	Pump 14	
2.3.5	Expansion vessel.....	14
2.3.6	By- pass	14
2.3.7	Filling sealed systems	14
2.3.8	Corrosion inhibitor	14
2.3.9	Draining	15
2.4.	Domestic hot water system.....	15
2.4.1	General 15	
2.4.2	Water pressure	15
2.4.3	HOT WATER FLOW RATE	15
2.4.4	Hard water areas	15
2.5.	Installation, PREPARATION [water connections].....	15
2.5.1	Water connections.....	15
2.5.2	Safety valve discharge	15
2.6	Electrical Installation Requirements	16
2.6.1	SUPPLY	17
2.6.2	19	
2.6.3	External Controls	19
	Electrical Connections.....	20
2.6.4	Supply cable connection [24 HR Supply]	20
2.6.5	Heating system controls	20
2.6.6	Electrical Test.....	20
2.6.7	Supply cable connection [Interrupted off peak supply]	21
2.6.8	Electrical Test.....	21
	Electricity tariffs	21

2.7 Commissioning	21
2.7.1 Filling domestic water circuit.....	21
2.7.2 Filling the heating system	21
2.7.3 Domestic hot water flow rate	22
2.7.4 Temperature settings.....	22
2.7.5 Heating system commissioning	22
2.7.6 Completion	23
Instruct the user.....	23
Part 3 - SERVICING	24
3.1. Fault Finding	24
Fault: No domestic hot water or central heating	25
Fault: No central heating, but hot water at taps.....	26
Fault: CENTRAL HEATING BUT No hot water at taps	27
3.2 ISOLATION	28
Checking the pressure in the expansion vessel	28
Checking the inline strainer	28
Checking the hot water blending valve.....	28
Checking the concentration of corrosion inhibitor.....	29
Preventing pump seizure in summer	29
Checking correct operation of electrical components.....	29
Low pressure switch.....	29
Control and high limit thermostats	29
Checking the elements.....	30
Checking circuit breakers	30
Checking the contactor.....	30
Check the operation of the AQUA STAT	30
Appendix I – Solar Connection.....	31
A1.1 Solar Pipe work Schematic	31
A1.2 Solar / Off peak Wiring Schematic	32

IMPORTANT PRE-INSTALLATION NOTES

- **Power supply and wiring**

The power supply to the premises must meet the minimum requirements of the unit being installed, with special attention given to the supply current, cable size and MCB recommendation. The supply voltage to the appliance must never drop below **207 Volts**.

Important

The electrical supply requirements:-

The 9 KW and 12 KW boilers meet the requirements of EN 61000-3.3

The 9 KW and 12 KW boilers must be installed in premises having a service supply of **≥ 100A** per phase.

The 12 KW boiler must be installed in premises having a system impedance of not more than **0.1939 + J 0.1939Ω**

0.1 Instructions general

A pressure reducing valve must be fitted to the cold water inlet if the incoming water pressure exceeds 400 KPA (4.0 Bar).

The primary operating pressure initial charge is 120 KPA (1.2Bar) this will increase to around 200 KPA (2.0Bar) when the system has reached maximum temperature and will depend on system volume.

The primary expansion vessel pre-charge pressure is 150 KPA (1.5 Bar) and has volume of 25 and 35 litres depending on the model of boiler.

The secondary expansion vessel pre-charge pressure is 350 KPA (3.5 Bar) and has a volume of 1 or 2 litres.

The primary pressure relief valve is set to 300 KPA (3.0 Bar).

	Thermaflow Model Number		
	TH9/210U & TH12/210U	TH9/250U & TH12/250U	TH9/330U & TH12/330U
Primary storage capacity	<i>210 litres</i>	<i>250 Litres</i>	<i>330 Litres</i>
Weight when Empty	<i>60KG</i>	<i>68KG</i>	<i>75KG</i>
Weight when Full	<i>270KG</i>	<i>318KG</i>	<i>405KG</i>

WARNING: BEFORE OBTAINING ACCESS TO TERMINALS, ALL SUPPLY CIRCUITS MUST BE DISCONNECTED.

The **TH9/210U**, **TH9/250U** and **TH9/330U** all have 3 heating elements fitted. Size 16” in length and are manufactured of Incaloy EN60335.2.73.

The rated power input of the appliance is ~230- 240V, 50Hz, 8,250-9,000w

The **TH12/210U**, **TH12/250U** and **TH12/330U** all have 4 heating elements fitted. Size 16” in length and are manufactured of Incaloy EN60335.2.73.

The rated power input of the appliance is ~230-240V, 50Hz, 11,000-12,000w

The elements fitted to the Thermaflow should NOT be replaced with elements which have no thermal cut outs.

It is recommended that the Thermaflow has a safety and maintenance check on an annual basis.

A pressure reducing valve must be fitted to the cold water inlet of the appliance if the incoming pressure exceeds 400kPA (4 Bar).

The position of the Tundish shall be visible to the occupants and shall be positioned away from any electrical devices.

The position of discharge pipes, (Tundish), drain valves and motorised valves etc, must be positioned away from electrical components.

The water may drip from the discharge pipe of the pressure-relief device and must be left open to the atmosphere.

The pressure relief device must be operated regularly to remove lime deposits and to verify that it is not blocked.

The discharge pipe connected to the pressure-relief device must be installed in a continuously downward direction and in a frost free environment.

(Additional Information given in G3 of the building regulations for discharge pipes)

0.2 Draining & Filling

CAUTION: THE THERMAFLOW BOILER WORKS IN A PRESSURISED SYSTEM WHICH MUST ONLY BE DRAINED, REFILLED AND PRESSURISED BY A COMPETENT PERSON.

There are two drain taps fitted to the Thermaflow boiler, one to drain the potable circuit within the boiler and one to drain the primary circuit within the boiler both drain taps are located at the bottom of the appliance. Further drain taps should be fitted into the pipe-work at the lowest point of the potable water circuit and the heating circuit and should terminate outside the dwelling in a suitable position.

0.3 Manual Handling Guidance

During the appliance installation it will be necessary to employ caution and assistance whilst lifting as the appliance exceeds the recommended weight for a one man lift.

DO NOT LIFT THE APPLIANCE BY ATTACHED PIPE-WORK OR COMPONENTS

In certain situations it may be required to use a mechanical handling aid.

Take care to avoid trip hazards, slippery or wet surfaces.

IMPORTANT INFORMATION

0.4 TESTING & CERTIFICATION

The boiler is tested and certified for safety and performance. It is therefore important that no alteration is made to the boiler, without permission, in writing, from Thermal Innovations (UK) Ltd.

Any alteration not approved by Thermal Innovations (UK) Ltd, could invalidate the certification, boiler warranty and may also infringe the current issue of the statutory requirements, see section 2.1.2

The unit should be stored in a dry environment and should be handled with care to prevent attached components being damaged or connections becoming loose. **All connections should be checked for leaks after installation.**

0.5 THE UNIT LOCATION

The unit should be preferably located in a cupboard with a minimum dimension of;

L 800 mm x B 700 mm H 2.1m for the **TH9/210U & TH12/210U.**

L 800 mm x B 700 mm X H2.4M for **TH9/250U & TH12/250U**

L. 820 mm x B. 700 mm x H. 2.4M for the **TH9/330U & TH12/330U.**

The floor to which the unit is placed upon should be capable of withstanding a load of:

270KG for the **TH9/210U & TH12/210U**

318KG for the **TH9/250U & TH12/250U**

405KG for the **TH9/330U & TH12/330U.**

The unit should be positioned in a manner that allows access to all components for future maintenance. If located in a cupboard the unit should be positioned with all components facing the entrance to allow elements to be replaced if required or any of the other components.

There are five water connections to be made when installing the Thermaflow, they are as follows:

1) Flow and return connections to the heating system are 22mm compression.

- 2) Cold water inlet-22mm compression.**
- 3) Hot water outlet -22mm compression.**
- 4) Pressure relief valve- 15mm compression with a 15mm- 22mm Tundish.**
- 5) The pressure relief valve connection should be used for no other purpose.**

PART1 - INSTRUCTIONS FOR USE

1.1 INTRODUCTION

This appliance is not intended for use by persons (including children) with reduced physical, sensory or mental capabilities, or lack of experience and knowledge, unless they have been given supervision or instruction concerning use of the appliance by a person responsible for their safety.

Children should be supervised to ensure they do not play with the appliance.

Please read these Instructions and follow them carefully for the safe and economical use of your combination boiler.

This boiler must have been installed by a competent person in accordance with the current rules in force in the countries of destination at the time of installation.

The boiler is automatic in operation once the external controls are set e.g. time clock or programmable room thermostat.

IMPORTANT NOTICE

1.2 Domestic hot water temperature

Hot water is user adjustable by turning the control knob on the thermostatic mixing valve fitted on the hot water outlet at the top left of the boiler. It has a maximum anti-scald cut off at 63oC.

The combination boiler is able to provide room heating as part of an under-floor or central heating system and domestic hot water direct from the cold water supply, without the need for secondary storage.

1.3 To turn the boiler off

To turn the boiler off, isolate the boiler from both the electrical supplies i.e. the 24hr supply and the interrupted supply, both isolating switches should be positioned next to the boiler.

1.4 Maintenance and servicing

To ensure the continued efficient and safe operation of the appliance it is recommended that it is checked and serviced as necessary at regular intervals. The frequency of servicing will depend upon the particular installation conditions and usage, but in general once a year should be enough.

Servicing & maintenance should be carried out by a **competent person** in accordance with the rules in force in the countries of destination.

To obtain service please call your installer or Thermal Innovations (UK) Ltd, using the telephone number on the appliance or at the front of this manual.

Please be advised that the Thermal Innovations (UK) Ltd log book should be completed by the installation engineer on completion of commission and servicing.

1.5 Clearances

The boiler requires a clearance in front and at the sides for safety, servicing and maintenance access, see **diagram 2.2.3** for the requirements.

1.6 Draining and filling

Caution this boiler works in a pressurised system which must only be drained, refilled and pressurised by a **person competent to do so**.

Note: if the pressure gauge indicates a loss of pressure that is less than 60 KPA (0.6 Bar).

YOU MUST CONTACT YOUR INSTALLER. Unless you have been instructed by your installer on how to re-pressurise the system correctly.

1.7 Replacement parts

If replacements parts are required, contact your Installer, Service Company or Thermal Innovations (UK) Ltd. Please quote the name and model of your appliance. (Ref. Spare Parts List - section 1.8.1).

1.8 GENERAL DATA

Diagram 1.8.1

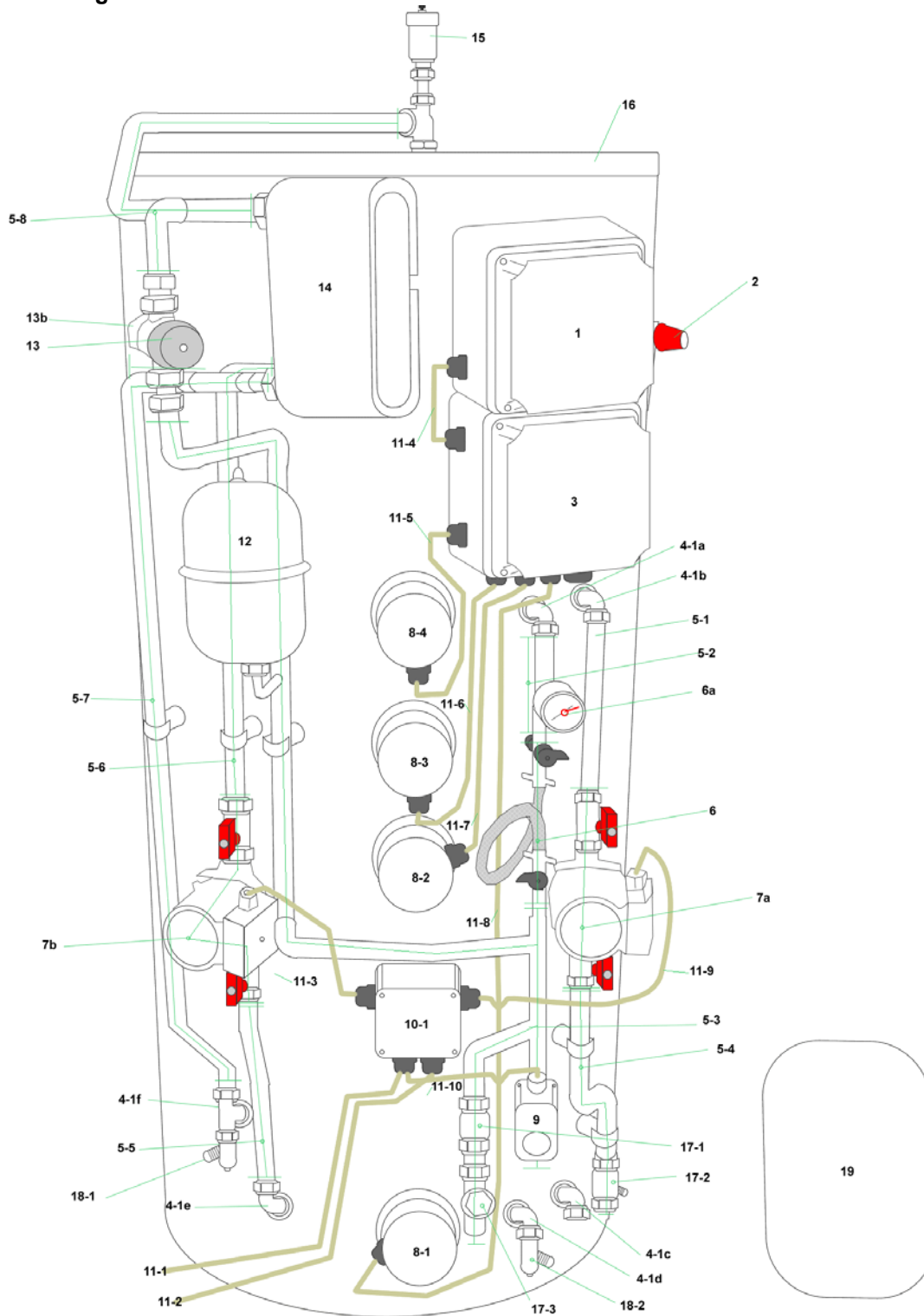

1	Enclosure for Low Pressure cut-out switch & Master non self reset over-temperature thermostat
2	Safety Relief Valve 300kPA (3bar)
3	Enclosure for Contactor and Circuit Breakers
4	22mm Compression bends DZR
5	Pipe work
6	Filling Loop Assembly 6a Pressure gauge
7	Circulating Pumps Complete with Isolating Valves. 7a – Grundfos Circulating Pump CH Circuit 7b – Grundfos circulating pump HW circuit
8	Heating Elements
9	Aqua Thermostat
10	10-1 Enclosure for incoming live supply, central heating pump & Aqua stat & pump for domestic HW circuit
11	Heat Resistant Flex
12	1 or 2 Litre Potable expansion vessel
13	Thermostatic Blending Valve 13b HW outlet
14	Plate Heat Exchanger
15	Automatic Air Eliminator
16	Stainless Steel Primary Store
17	17-1 Single check valve – cold water inlet 17-2 Single check valve – CH flow 17-3 Y-pattern strainer (cold water inlet)
18	18-1 Drain point (potable) 18-2 Drain point (primary)
19	Primary Expansion vessel – connect into CH return at boiler

Unit Design (Protected by Design Rights)

TABLE 1.8.1 [DATA]

	TH9/12/210	TH9/12/250	TH9/12/330
Lift Weight	60KG	68KG	75KG
Total Weight	70KG	77KG	85KG
Weight Full	270KG	318KG	405KG
Heating Flow Return	22mm Compression		
Domestic Cold Inlet	22mm Compression		
Domestic Hot Outlet	22mm Compression		
Safety Valve	PRESET 300 KPA (3.0 Bar)		
Safety Valve Discharge	15mm Compression		
Water Content Primary	204 Litres	244 Litres	324 Litres
Water Content Domestic	6 Litres / 1.32 Gallons		
Primary Expansion Vessel	25 Litres / 5.5 Gallons / 35Litres/7.7 Gallons		
Htg Cold Fill Pressure Min/Max	90 KPA (0.9 Bar) minimum / 120 KPA (1.2 Bar) maximum		
D.H.W Working Pressure	20 – 400 KPA (0.2-4.0 Bar)		
Max. Htg system Content (Excluding unit volume)	110Litres	130Litres	150Litres
Electrical Mains Supply	~230-240V, 50Hz		
Electrical Rating (Interrupted) & Supply Current	TH9/ 8,250-9,000w- 40amp TH12/ 11, 000-12,000w – 52 amp		
MCB Rating (amp)	9Kw (40amp) 12Kw (52amp)		
Electrical Rating (24Hr	190w, Fused 3amp		

PART 2 - INSTALLATION

2.1.1 Sheet metal parts

Warning: when installing or servicing this boiler care should be taken when handling the edges of metal parts to avoid any possibility of personal injury.

2.1.2 Statutory requirements

The installation of this boiler must be carried out by a competent person in accordance with the current rules in force in the countries of destination at the time of installation, and in accordance with the relevant requirements of the current issue of:

The Building Regulations

The Local Water Company bye-laws

The Building Standards Regulations (Scotland)

The Health and Safety at Work Act

Manufacturers instructions, supplied

Manufacturer's instructions must not be taken as overriding statutory requirements.

2.1.3 DATA

The data label is on the front case of the boiler.

2.1.4 ELECTRICAL SUPPLY

- **Power supply and wiring**

The power supply to the premises must meet the minimum requirements of the unit being installed, with special attention given to the supply current, cable size and MCB recommendation. The supply voltage to the appliance must never drop below **207 Volts**.

Important

The electrical supply requirements:-

The 9 KW and 12 KW boilers meet the requirements of EN 61000-3.3

The 9 KW and 12 KW boilers must be installed in premises having a service supply of $\geq 100A$ per phase.

The 12 KW boiler must be installed in premises having a system impedance of not more than **0.1939 + J 0.1939 Ω**

WARNING: This boiler must be earthed

WARNING: Means for disconnection must be incorporated in the fixed wiring in accordance with the wiring rules

WARNING: Electrical work must be carried out by a person competent to do so

All system components shall be of an approved type.

The electrical installation shall be in accordance with the current rules in force in the countries of destination at the time of installation.

2.1.5 Electrical supply

Means of disconnection of the electrical supply to the boiler must be incorporated in the fixed wiring in accordance with the wiring rules.

Two isolators are required, one for the 24hr supply, and the other for the interrupted supply (off peak if available)

Means of disconnection of the 24hr supply should be by a double pole switched fused spur box (fuse rating 3 amp), having a minimum contact separation of 3mm in each pole. The fused spur box should be readily accessible and adjacent to the appliance. It should be identified as to its use.

Means of disconnection should not be fitted in a room containing a fixed bath or shower. The 24hr mains supply cable and other cables for external controls must be heat resistant and flexible PVC type of at least 0.75mm² (24/ 0.20mm)

Means of disconnection of the interrupted supply (off peak) should be by a double pole switched (60amp isolator with a 40 amp MCB **Type C** for the TH9/ model) and a switched (100 amp isolator with a 63 amp MCB **Type C** for the TH12/ model), having a minimum contact separation of 3mm in each pole. The switched isolator should be readily accessible and adjacent to the appliance. It should be identified as to its use.

Means of disconnection should be readily accessible and adjacent to the appliance. It should be identified as to its use.

The interrupted mains supply cable must have a cross sectional area of at least (10mm² for the TH9/ model) and (16mm² for the TH12/ model). The mains supply cable from the isolator to the boiler should be preferably encased by flexible conduit.

2.1.6 Heating system controls

The heating system should have installed: A timer and room thermostat or a programmable room thermostat controlling the central heating system.

Thermostatic radiator valves should be installed in addition to the room thermostat for better economy and energy saving.

2.2.1 Boiler Position

The boiler must be installed in accordance with the rules in force in the countries of destination. This boiler is not suitable for fitting outside.

Any electrical switch must be positioned so that it cannot be touched by a person using the bath or shower.

The boiler must be positioned on a level base or floor which is sufficiently robust to take its weight, (Refer to table 1, "Data")

If the location of the boiler or any part of the system is subject to severe cold weather conditions, it is recommended that a frost thermostat is fitted. Any part of the system that may be vulnerable to freezing must be protected.

2.2.2 Boilers in a compartment

Where the installation of the boiler will be in an unusual position, the current issue of BS 6798 gives detailed guidance on these requirements.

An existing cupboard or compartment modified for the purpose may be used, providing minimum clearances are maintained. Details of essential requirements for cupboards or compartment design are given in the current issue of BS6798.

The doorway opening should be of sufficient size to allow for easy removal of the boiler.

Where the boiler is fitted in a cupboard or compartment permanent ventilation is not required. Compartment ventilation is required to dissipate heat from any external heating circuit pipe-work, to prevent overheating of the electrical components and wiring.

Any existing compartment air vents must not be removed or blocked off.

2.2.3 Clearances

The boiler should be positioned so that at least the minimum operational and servicing clearances are provided, see diagram 2.2.3 additional clearances may be required around the boiler for installation. A clearance of 600mm is required at the front of the boiler for maintenance and installation.

Diagram 2.2.3 - Clearances

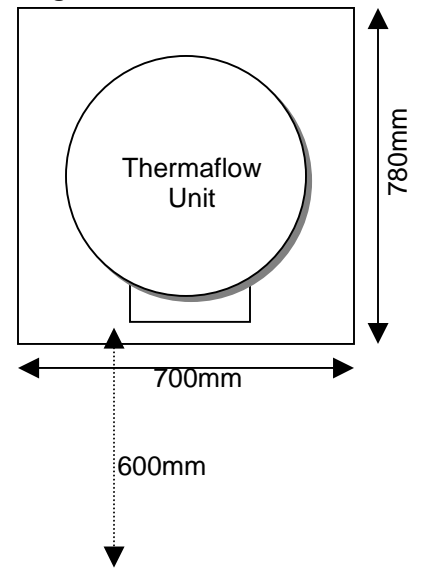

2.3.1 General notes

The boiler is intended for use in a sealed system only.

2.3.2 Safety valve

The safety relief valve is an integral part of the boiler. It cannot be adjusted but has a manual test device.

2.3.3 Pressure Gauge

A pressure gauge is incorporated into the boiler to indicate the system pressure. The gauge has a cold fill set pointer.

2.3.4 Pump

The circulation pump is integral with the boiler.

2.3.5 Expansion vessel

The **TH9/210U & TH12/210U** and **TH9/250 & TH12/250U** are both supplied with an expansion vessel with a capacity of **25** litres and the **TH9/330U & TH12/330U** is supplied with a **35** litre expansion vessel. If the system water content exceeds the maximum quoted in **table 1, [Data]** an additional vessel should be connected into the system as close as possible to the central heating return connection of the boiler. **Ref. Diagram 2.3.5**

Diagram 2.3.5

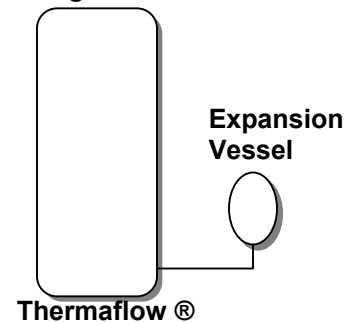

The charge pressure shall not be less than the static head at the point of connection, which is the height of the top point of the system above the expansion vessel.

2.3.6 By- pass

An automatic by- pass valve should be incorporated in the system for maximum system efficiency. (A By-Pass MUST be fitted on all models).

2.3.7 Filling sealed systems

The boiler has a filling loop incorporated within it, and pressure gauge to register the fill pressure.

There must be no permanent connection to the mains water supply; even though a non return valve is supplied. **Disconnect filling loop and seal both valves with suitable caps.**

2.3.8 Corrosion inhibitor

The maintenance of sufficient concentration of corrosion inhibitor in your Thermaflow system is vital to prevent corrosion. We would recommend sentinel X100, or equivalent. Dose appropriately according to the size of the Thermaflow and central heating system volume combined.

2.3.9 Draining

A draining tap must be provided at the lowest points of the system, which will allow the entire system to be drained. The boiler has two drain taps fitted to it one for primary and one for secondary.

2.4. Domestic hot water system

2.4.1 General

The domestic hot water service must be in accordance with the rules in force in the countries of destination.

2.4.2 Water pressure

For the minimum and maximum, working pressures of the domestic hot water circuit of the boiler refer to (“data” table 1).

If the cold water inlet pressure exceeds 400 KPA (4 Bar) a pressure reducing valve must be fitted to the inlet to the boiler.

2.4.3 HOT WATER FLOW RATE

The boiler is capable of flow rates of **20-30 litres per/min @ 40°C Δt (depending on model)**. Hot water flow rate and pressure will be determined by the volume and pressure of the incoming cold water supply.

2.4.4 Hard water areas

In areas where the water is “Hard” more than 200 mg / Litre, it is recommended that a proprietary scale reducer or water softener is fitted in the cold water supply to the boiler. Consult the local water authority for additional advice.

A double check valve assembly must be fitted upstream of the scale reducer/water softener, for the relative position of the scale reducer/water softener and pressure reducing valve, if required, refer to the manufacturers instructions.

2.5. Installation, PREPARATION [water connections]

2.5.1 Water connections

See General Data Diagram 1.8.1 & table 1.8.1 for pipe work connections

It is recommended to flush out the domestic water and heating system before connecting to the boiler.

While making the connections, do not subject any of the connections to heat as you may damage the seals.

2.5.2 Safety valve discharge

It must not discharge above an entrance or window or any type of public access.

The position of the Tundish shall be visible to the occupants and shall be positioned away from any electrical devices.

The position of discharge pipes (Tundish) drain valves and motorised valves etc must be positioned away from electrical components.

The water may drip from the discharge pipe of the pressure-relief device and must be left open to the atmosphere.

The pressure relief device must be operated regularly to remove lime deposits and to verify that it is not blocked.

The discharge pipe connected to the pressure-relief device must be installed in a continuously downward direction and in a frost free environment.

The connection for the discharge is made at the bottom side of the safety relief valve. A tundish should be fitted by the installer in accordance with G3 of the current building regulations.

This must be extended, using not less than 15mm O.D. metal pipe, to discharge, in a visible position, outside the building, facing downwards, preferably over a drain. The pipe must have a continuous fall and be routed to a position so that discharge water, possibly boiling or steam, cannot create any danger to persons, damage to property or external electrical components and wiring.

2.6 Electrical Installation Requirements

- **Power supply and wiring**

The power supply to the premises must meet the minimum requirements of the unit being installed, with special attention given to the supply current, cable size and MCB recommendation. The supply voltage to the appliance must never drop below **207 Volts**.

Important

The electrical supply requirements:-

The 9 KW and 12 KW boilers meet the requirements of EN 61000-3.3

The 9 KW and 12 KW boilers must be installed in premises having a service supply of **≥ 100A** per phase.

The 12 KW boiler must be installed in premises having a system impedance of not more than **0.1939 + J 0.1939Ω**

2.6.1 SUPPLY

The boiler requires two separate ~230-240V power supplies. A (24HR) supply for controls and an interruptible supply for the boiler. **(Off Peak power supply if it is available).**

The off peak or interruptible mains supply is wired according to the following **diagram 2.6.1**, from the 63 amp double pole isolator by way of flexible 16mm² cable into the main terminals in enclosure marked **No. 3** on the boiler schematic **diagram 1.8.1**, see **diagram 2.6.1** below.

Diagram 2.6.1

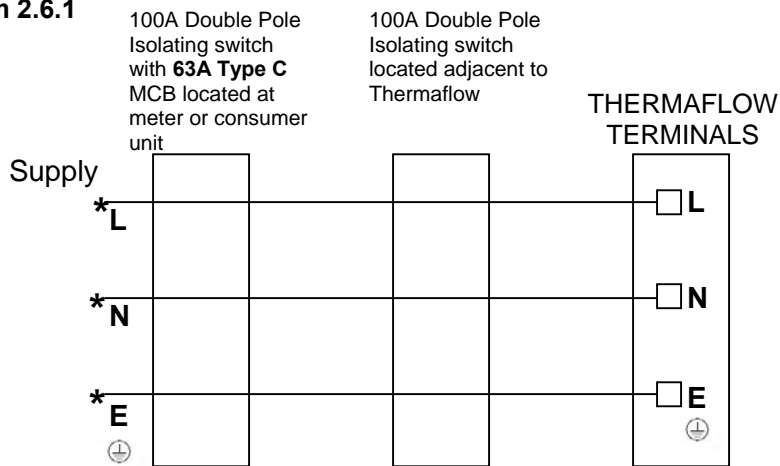

* 25mm² COLOUR CODED METER TAILS
CONNECT TO METER / TELE-SWITCH

Cable Sizing

Boiler Rating Minimum Cable Size ~230-240V-50Hz, (8,250-9,000w - 10mm²) and (11,000-12,000w – 16mm²). **MCB MUST BE TYPE C**

Diagram 2.6.2a

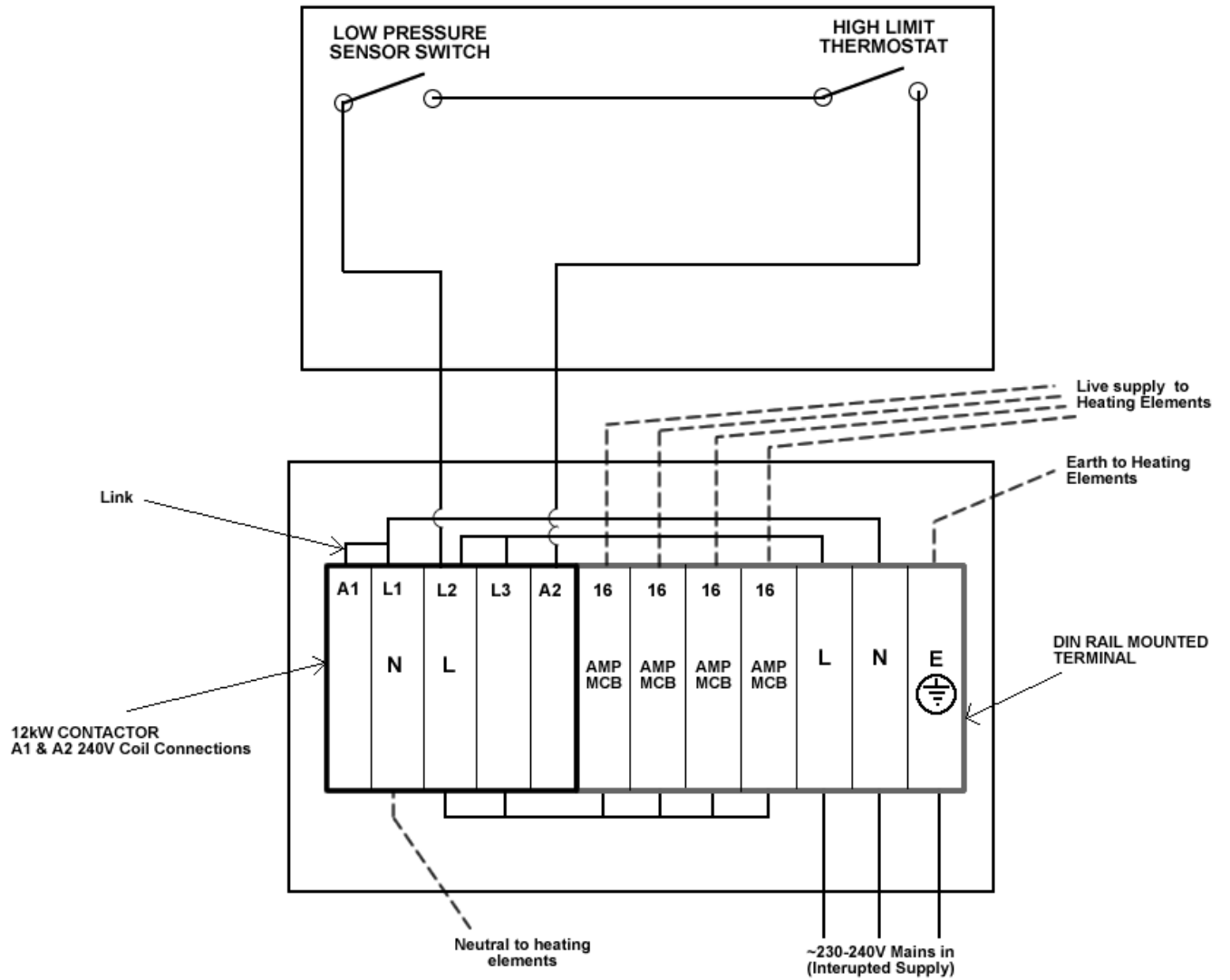

2.6.2

The mains supply into the enclosure marked **No 10.1** on the boiler diagram should be wired to the 24HR supply via 3 Amp fused isolating switch located at the boiler, **ref. diagram 2.6.2a**.

Diagram 2.6.2b

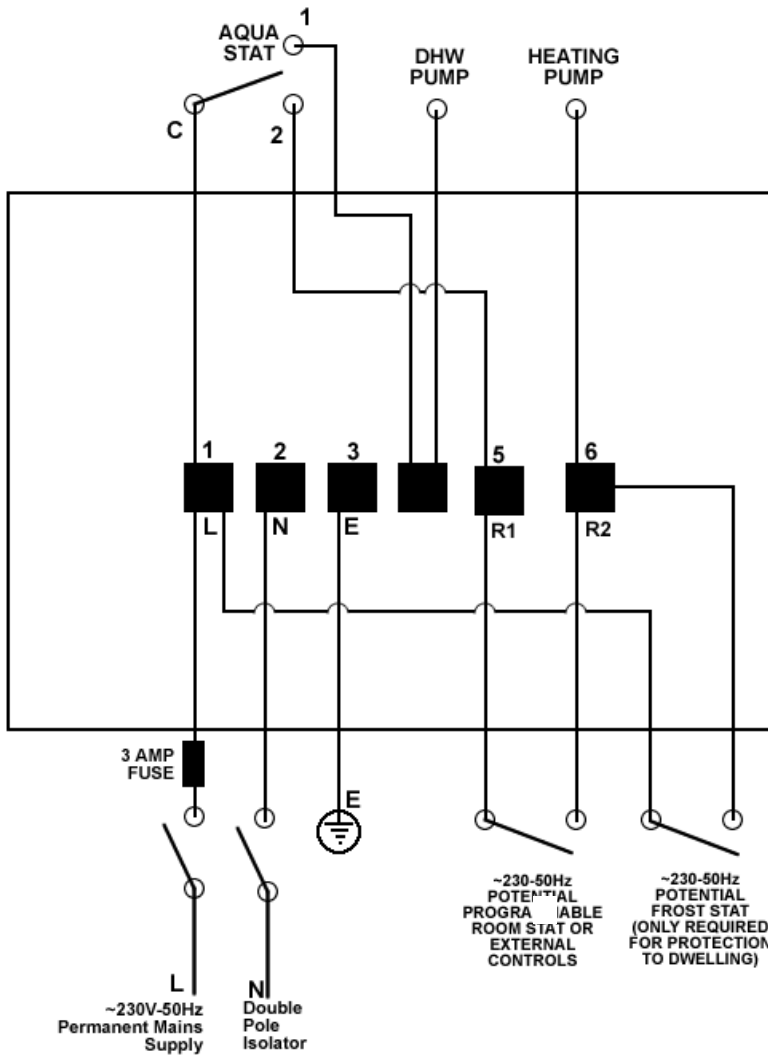

2.6.3 External Controls

External heating controls should be connected to the terminals marked R1 & R2 shown in **diagram 2.6.2b**. All external controls should be connected to terminals marked R1 & R2 in the enclosure marked **No 10.1** in the boiler schematic **diagram 1.8.1**.

WARNING: ALL EXTERNAL CONTROLS MUST NOT BE TAKEN FROM ANY OTHER POWER SUPPLY OTHER THAN VIA THE 3 AMP FUSED ISOLATING SWITCH MENTIONED ABOVE.

Electrical Connections

2.6.4 Supply cable connection [24 HR Supply]

Caution: To prevent an induced current from switching the central heating on when not required it is important that the heating system control cables are separated from the other mains cables.

There is provided 2 heat resistant cables extending from the enclosure situated between both circulating pumps. One cable has 3 cores. Live, Neutral and earth to be connected to a 3 amp double pole fused isolator. The other cable has 2 cores coloured brown and (blue core covered with brown sleeve) these are both common live and switched live wires to be connected to external heating controls.

The boiler requires a permanent mains supply through an external isolator (**rated to 3amp**) which must isolate any heating system controls see **diagram 2.6.2b**

Any heating system controls must not interrupt the permanent mains supply to the boiler.

Standard colours are **Brown- Live, Blue- Neutral and Green and yellow- Earth**. Make the earth cable of a greater length so that if the cable becomes strained the earth would be the last to become disconnected.

CAUTION: IT IS ESSENTIAL TO MAKE SURE THAT THE POLARITY IS CORRECT.

2.6.5 Heating system controls

All external controls and wiring are required to provide a minimum of reinforced insulation at 250 vrms between the parts of those devices operating at mains hazardous voltage and the user accessible parts of those devices.

Note: for further information, see the building regulations 1991- conservation of fuel and power, 1995 edition- appendix G, table 4B.

When any kind of external heating system controls are being used to regulate the heating system connect a single pole type, to the appropriate terminals of the connector shown in **diagram 2.6.2b, or (to the 2 core cable provided)**.

If the installation requires protection by a "Frost Thermostat" connect a single pole type, to the appropriate terminals of the connector shown in **diagram 2.6.2b**.

2.6.6 Electrical Test

Carry out preliminary electrical system checks as below.

- 1) Test insulation resistance to earth of mains cables.
- 2) Test earth continuity and short circuit of all cables.
- 3 Test the polarity of the mains.
- 4 Refit the enclosure cover.

2.6.7 Supply cable connection [Interrupted off peak supply]

Open the lower of the two enclosures situated at the top of the boiler.

Using 16mm² twin and earth cable of a suitable length route the mains interrupted supply cable through a piece of suitably sized flexible conduit from the 100amp isolator into the terminals shown in diagram 5.

Standard colours are Brown- Live, Blue- Neutral and the earth should be sleeved with a suitably sized green and yellow earth sleeve.

Make the earth cable of a greater length so that if the cable is strained the earth would be the last to become disconnected.

CAUTION: IT IS ESSENTIAL TO MAKE SURE THE POLARITY IS CORRECT.

2.6.8 Electrical Test

Carry out preliminary electrical system check as below:

- 1) Test insulation resistance to earth, of mains cables.
- 2 Test earth continuity and short circuit of all cables
- 3 Test the polarity of the mains.
- 4 Refit the enclosure cover.

Electricity tariffs

The Thermaflow will operate on any ~230-240V, 50Hz supply. The most economical option is a peak avoidance tariff as described previously.

Scottish Power, Eastern Energy, Guernsey Electric North Eastern Electricity all have an 18 hour tariff. Other areas offer their own tariffs, which may be viable for economic operation.

2.7 Commissioning

2.7.1 Filling domestic water circuit

Check that the boiler is isolated from the electrical supply, at both external isolators.

Fully open the domestic water supply stop cock or valve in the supply to the boiler.

Open all hot water draw-off taps and close them when water flows. Check for water soundness of the whole domestic hot water installation and boiler.

2.7.2 Filling the heating system

Flush, fill and vent the system refer to section 3.7 "Filling sealed systems".

The boiler and central heating system should be completely filled and purged of air before switching on the power

to the appliance. The cold fill pressure should register no more than 120 KPA (1.2 Bar). **See Table 1.8.1 (DATA), for minimum and maximum pressures.**

Make sure the automatic air vent at the top of the boiler is operating correctly.

IMPORTANT

MAKE SURE THE BOILER AND SYSTEM IS COMPLETELY FULL OF WATER AND ALL AIR IS ELIMINATED BEFORE TURNING ON ANY OF THE POWER SUPPLIES TO THE BOILER.

Take care not to splash any of the electrical components.

Pressurise the system until the pressure is 150 KPA (1.5 Bar). **Check the heating system and boiler for water soundness.**

Check the operation of the safety valve by turning the safety valve knob in the direction of the arrow.

Lower the pressure to the initial cold fill design pressure of 120 KPA (1.2 Bar), **refer to table 1.8.1.** Position the set pointer on the boiler pressure gauge at this pressure also.

NOTE: When the boiler reaches its maximum temperature, the pressure will increase to around 200 KPA (2.0 Bar)

2.7.3 Domestic hot water flow rate

The domestic hot water flow rate can be set by adjusting the stop cock on the cold water inlet to the boiler.

2.7.4 Temperature settings

The maximum temperature setting for the domestic hot water is 60oC but is user adjustable by altering the setting on the hot water mixing valve on the boiler.

The maximum flow temperature setting for central heating is 82oC this is the preset and is not adjustable.

2.7.5 Heating system commissioning

Make sure the boiler and heating system is completely full of water. (SEE ABOVE SECTION 7.2)

Turn on both 24Hr & Interrupted power supplies. Allow approximately 120 - 200 minutes to bring the boiler up to temperature (depending on model). Check that all external controls, are calling for heat.

Fully open all thermostatic and lock shield valves on each radiator.

Set the aqua stat, positioned at the bottom of the boiler to **30°C (It must remain at this setting)**

Allow this system to reach maximum temperature then switch off both electrical supplies at the isolators. Drain the system rapidly while still hot.

Fill and vent the system as described in section 7.2 "Filling the central heating circuit" Add inhibitor as required refer to section 3.8 "Corrosion Inhibitor"

Set to the initial cold fill design pressure, using the external draining tap. Refer to table 1, and section

3.9

NOTE: The system fill pressure may require to be recharged once or twice in the first two to three weeks after the initial commissioning of the boiler due to oxygen in the system being expelled through the automatic air eliminator. There should be no further need to re-pressurise the system after this period. If the system requires continuous re-pressurisation, there may be a leak in the installation.

2.7.6 Completion

Set any external heating control to the desired settings.

Instruct the user

Instruct and demonstrate the isolating switches then advise the user of the efficient and safe operation of the boiler.

Instruct and demonstrate the operation of any heating system controls.

Advise the user on the use and maintenance of any scale reducer and pass on any relevant instructional documents.

Advise the user that to ensure continued efficient and safe operation of the appliance, it is recommended that it is checked and serviced at regular intervals. The frequency of servicing will depend on the particular installation and usage, but in general once a year should be enough.

Any servicing should be carried out by a person competent to do so.

Advise the user of the precautions necessary to prevent damage to the system and building in the event of the heating system being out of use during frost and freezing conditions.

Reminder- leave these instructions with the user.

Advise the user that the logbook should be completed by the engineer on completion of commissioning. **Failure to do so will invalidate the warranty.** The user must sign the log book and retain it for future reference.

PART 3 - SERVICING

3.1. Fault Finding

MUST BE CARRIED OUT BY A PERSON COMPETENT TO DO SO

Before trying to operate the boiler make sure that:

The heating system pressure is at 120 KPA (1.2 Bar) when the system is **cold** and 200 KPA (2.0 Bar) when the system is at **maximum** temperature.

There is a permanent mains power, (24hr supply) to the terminals marked in the controls enclosure at the bottom of the boiler (Marked No **10-1** on the boiler schematic diagram 1.8.1).

There is power at the off peak (Interrupted) supply main switch in the lower enclosure at the top of the boiler (Marked No **3** on the boiler schematic diagram 1.8.1).

WARNING: BEFORE OBTAINING ACCESS TO TERMINALS, ALL SUPPLY CIRCUITS MUST BE DISCONNECTED.

IMPORTANT: ON COMPLETION OF THE FAULT FINDING TASK WHICH HAS REQUIRED THE BREAKING OR REMAKING OF THE ELECTRICAL CONNECTIONS, THE CONTINUITY, POLARITY, SHORT CIRCUIT AND RESISTANCE TO EARTH CHECKS MUST BE REPEATED USING A SUITABLE MULTI- METER.

Type of fault	Check
No domestic hot water or central heating	~230-240V Supply (24HR) ~230-240V Supply (Off Peak) System water pressure Master high limit thermostat Contactor Reset-able Over Heat Thermostats Heating elements
No central heating but hot water at taps	~230-240V Supply (24HR) ~230-240V Supply (Off Peak) External controls Heating elements Reset-able Over Heat Thermostats Temperature at bottom of store must be above aqua stat setting of 30°C Central heating pump
Central heating but no hot water at taps or temperature diminishes after a short period	Auto air eliminator in closed position Pump valves in the open position? Figure 3 , Diagram 1.8.1) Domestic hot water pump

Fault: No domestic hot water or central heating

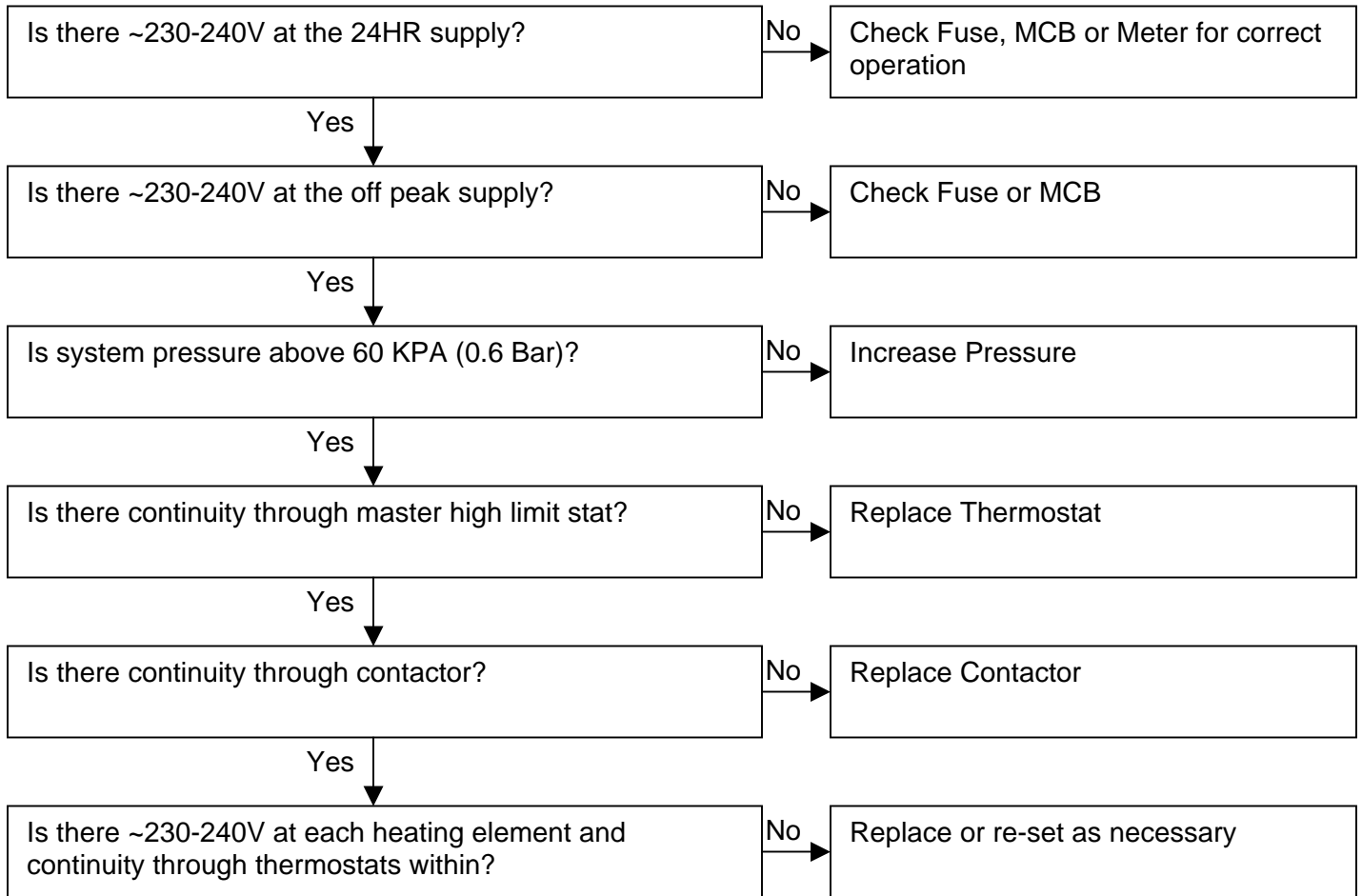

Fault: No central heating, but hot water at taps

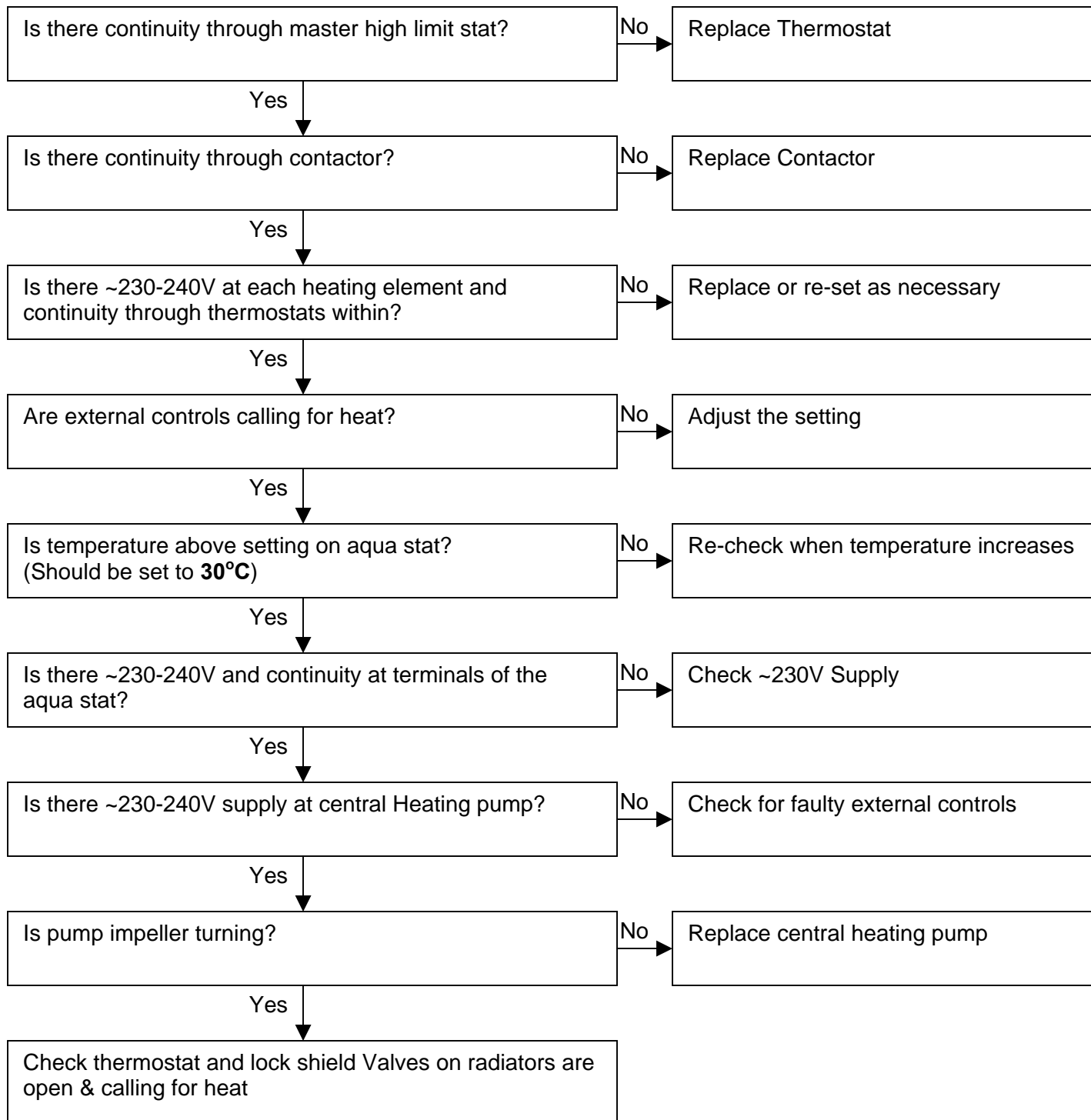

Fault: CENTRAL HEATING BUT No hot water at taps

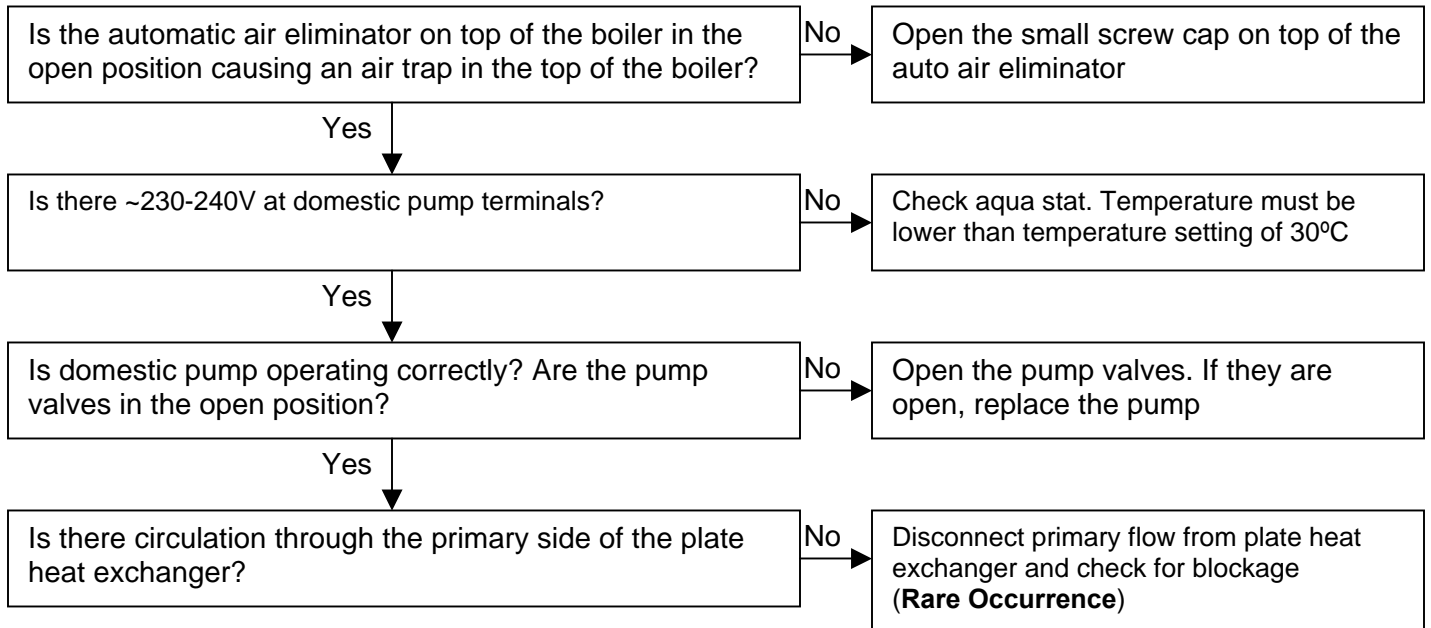

WARNING: FOR YOUR OWN SAFETY

SERVICING AND MAINTENANCE SHOULD BE CARRIED OUT BY A PERSON WHO IS COMPETENT TO DO SO.

3.2 ISOLATION

- Before commencing, refer to section 1. Installation

Checking the pressure in the expansion vessel

The primary expansion vessel (volume 25 or 35 litres) is the red or blue vessel connected to the central heating return pipe near to the boiler. Its purpose is to take up expansion in the boiler and central heating system.

The pressure can be accurately checked with the pressure relieved on the other side of the diaphragm. To do this drain some water from the central heating system until the pressure gauge registers zero. Connect a pressure gauge to the car tyre type valve on the vessel. The pressure should register 150 KPA (1.5 Bar). Refill heating system as described in section **2.7.2**

The secondary expansion vessel (volume 2 litres) is the white or silver vessel connected to the cold inlet of the plate heat exchanger.

Its function is to take up expansion in the hot water pipe work and so protect the blender from damage.

The pressure can be accurately checked with the pressure relieved on the other side of the diaphragm. To do this, isolate the water supply to the Thermaflow and open a hot tap. Water will run for a few seconds then stop.

Connect a pressure gauge to the car tyre type valve on the vessel. The pressure should register 350 KPA (3.5 Bar). Close the hot taps and turn the water supply back on.

Checking the inline strainer

Whilst the water is off, remove and clean the gauze in the brass strainer assembly. To remove the gauze for cleaning un-screw the brass plug.

Checking the hot water blending valve

With the store temperature fully recovered, run a hot tap and check the flow rate and temperature. If the hot water has deteriorated suddenly (over less than a month) then this points to a problem with the blender.

A broken blender is usually linked to a loss of pressure in the secondary expansion vessel. The expansion vessel protects the blender from damage when the water in the secondary system expands as the water re-heats after water is drawn off.

Check the pressure in the secondary expansion vessel as detailed previously in section 2. If it does not hold pressure it will need to be changed along with the blender.

Strip off the blender and check hot and cold mesh filters for blockage. (Clean if necessary).

Checking the concentration of corrosion inhibitor

We would recommend Sentinel X100, or equivalent. Dose appropriately according to the size of the Thermaflow and central heating system volume combined and in accordance with the inhibitor manufacturer's guidelines.

Preventing pump seizure in summer

To prevent seizure of the central heating pump we recommend you turn the central heating on for 30 seconds or so every few weeks throughout the summer.

Seized pumps can usually be freed. The air release on the pump can be completely removed. A small flat blade screwdriver can be inserted into the slot in the centre and rotated to free the pump.

Checking correct operation of electrical components

WARNING: BEFORE OBTAINING ACCESS TO TERMINALS, ALL SUPPLY CIRCUITS MUST BE DISCONNECTED.

Low pressure switch

To check correct operation of the low pressure switch, drain some water from the central heating system until the pressure falls below 0.5 bar, then check continuity between terminals 1 and 2 there should be no continuity between these terminals. Re pressurise the boiler and re check there is continuity between the same terminals.

Control and high limit thermostats

Check operation of the control and over temperature thermostats by checking for continuity between both terminals. (YOU MAY HAVE TO REMOVE THESE THERMOSTATS IF THE BOILER IS STILL HOLDING HOT WATER. YOU CAN PLACE THE THERMOSTATS IN A BEAKER OF COLD WATER AND THEN CHECK FOR CONTINUITY ACROSS THE THERMOSTAT).

CONTROL THERMOSTATS; there are three or four of these thermostats in total, one in each element. The control thermostats are individually preset and sealed; they should not be tampered with. If a failure on one of the thermostats has occurred, take note of which element it was removed from and contact Thermal Innovations (UK) Ltd for spares and advice.

OVER TEMPERATURE THERMOSTATS (Manual reset); there is also three or four of these, one in each element. The over temperature thermostats are individually preset and sealed they should not be tampered with. If a failure on one of the thermostats has occurred, reset the thermostat by pressing the small reset button on the thermostat. If the thermostat continues to fail in an overheat condition, take note of which element it was removed from and contact Thermal Innovations (UK) Ltd for spares and advice.

There is also a non reset-able over temperature thermostat in the top enclosure this is the master over temperature thermostat, this will break the circuit on over temperature it is preset and sealed and should not be tampered with. This thermostat is not reset-able and will have to be **replaced** if it has incurred an overheat situation). **This will indicate a fault has occurred elsewhere and will have to be investigated and rectified before the appliance is turned back on for use.** If a failure has occurred, contact Thermal Innovations (UK) Ltd for spares and advice.

Checking the elements

Check the continuity between live and neutral terminals on the element. Replace the element if there is no continuity.

Checking circuit breakers

Switch each circuit breaker off in turn and check that continuity is broken to each element.

Checking the contactor

Turn the main isolator off (this should be situated adjacent to the boiler) you should hear a dull thump from the enclosure marked number **3** on the boiler schematic **diagram 1.8.1**. This indicates that the contactor has disconnected the circuit to the MCB's and in turn the heating elements. Turn the main isolator on and off a few times and listen for this noise. This will indicate correct operation of the contactor.

Check the operation of the AQUA STAT

The Aqua Stat is positioned above the bottom element on the boiler. **Make sure the external controls are calling for heat.** Turn the dial on the thermostat up and down and listen for a small click. As you turn the thermostat dial up and down check if the central heating pump, (**positioned on the right side of the unit**) is switching **on** and **off** and do the same with the DHW pump on the left hand side. If this is the case, this indicates correct operation of the thermostat.

APPENDIX I – SOLAR CONNECTION

A1.1 Solar Pipe work Schematic

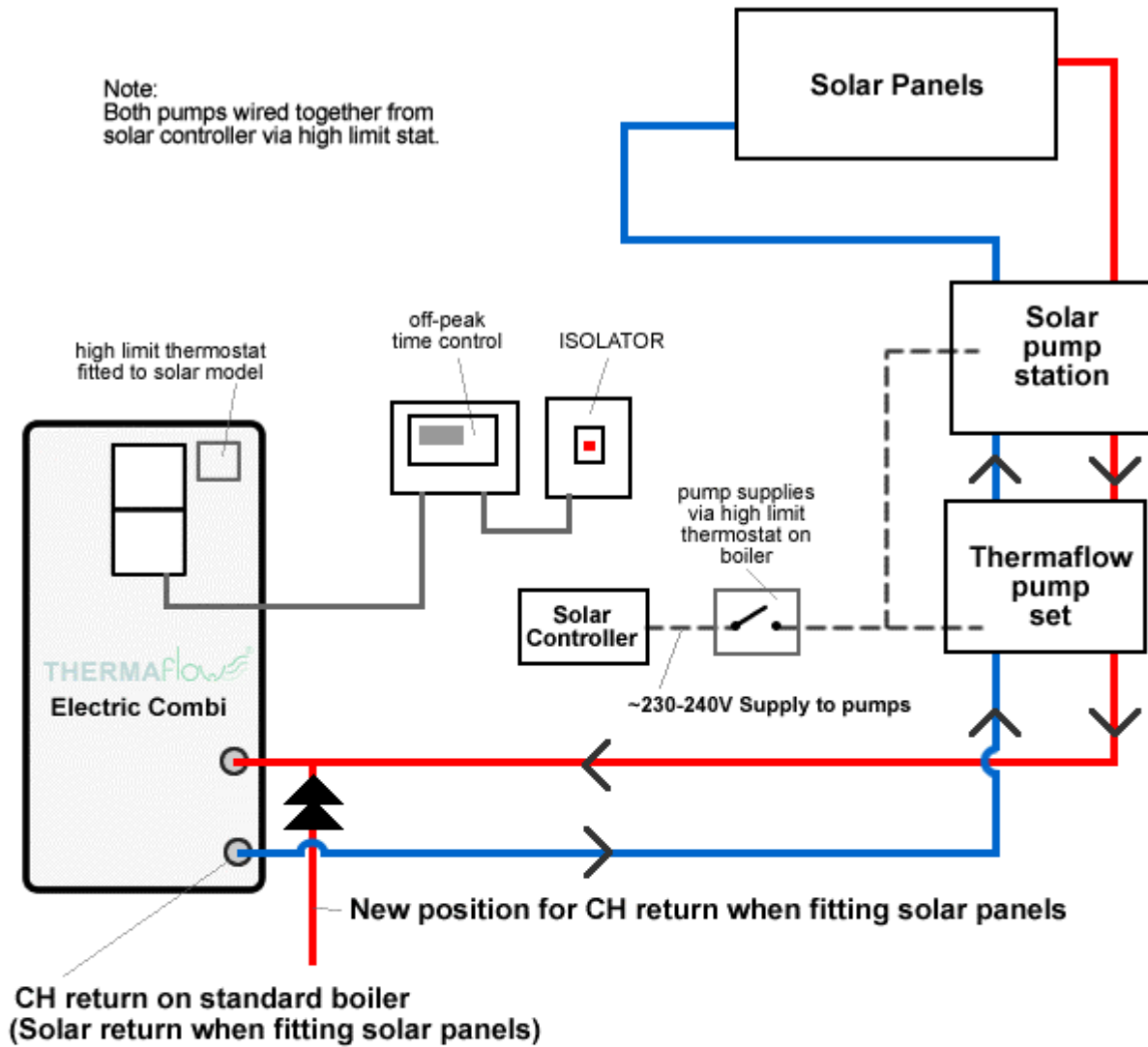

Connect primary expansion vessel into solar return when fitting solar panels

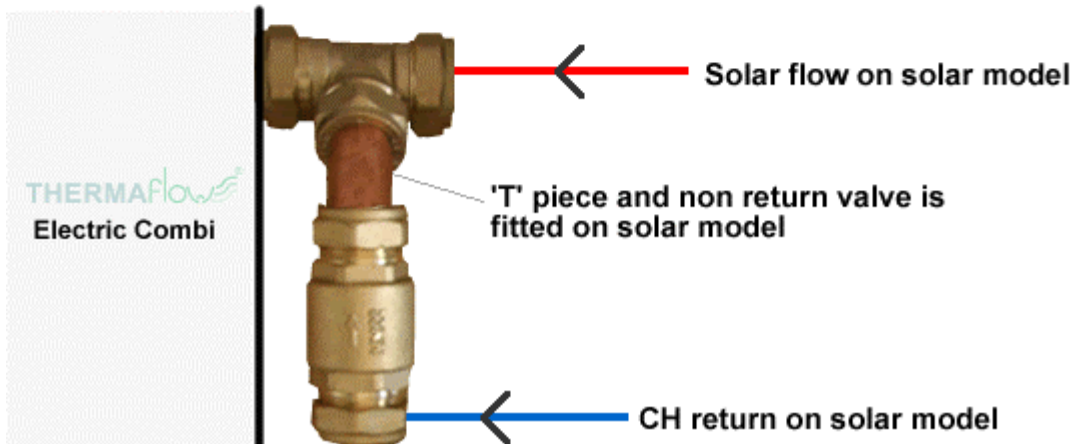

A1.2 Solar / Off -Peak Wiring Schematic

